

Eclipse 2.0

Heavy Duty Cantilever Umbrella

- Commercial-grade quality for your home
- Full 360° rotation to maximise shade coverage
- Unlimited tilt positions to block out low afternoon sun
- Marine-grade materials
- Heavy duty construction can stay outside all year round
- Easy installation options
- Can be braced with (optional) stabiliser bars for additional wind stability
- Engineer wind rated and Australian Certificate of Compliance Design
- Australia's Best Umbrella Warranty



65 km/h
Wind Rating



The Eclipse 2.0

Australia's Best Cantilever Umbrella

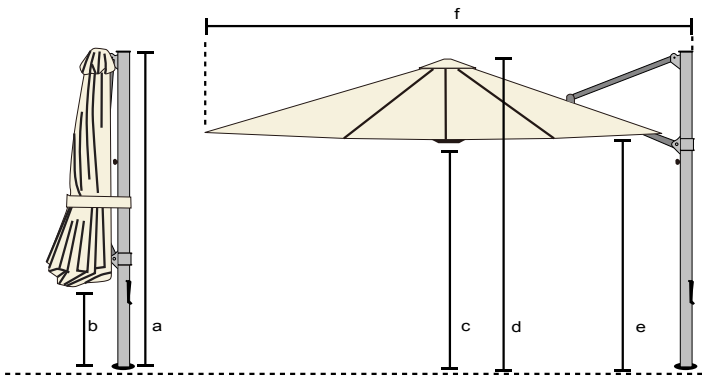

Dimensions

*All measurements are rounded and are subject to change.

Dimensions of closed umbrella

| | 3m sq | 4m oct | 3.5m sq |
|--------------------------------------|-------|--------|---------|
| a: Mast height (cm) | 283 | 283 | 283 |
| b: Distance from arms to ground (cm) | 68 | 80 | 35 |
| Weight of umbrella when folded (kg) | 35 | 37 | 37 |

Dimensions of open umbrella

| | | | |
|---|-----|-----|-----|
| c: Height to canopy hub (cm) | 205 | 207 | 212 |
| e: Height to edge of canopy (cm) | 283 | 275 | 289 |
| d: Total height to top of canopy (cm) | 210 | 210 | 210 |
| f: Distance from back of mast to front tip of canopy (cm) | 329 | 405 | 375 |
| Width of canopy (cm) | 300 | 400 | 350 |

Packaging dimensions

| | | | |
|---|-----------|-----------|-----------|
| Dimensions of cardboard packaging (cm) | 295x51x30 | 295x51x30 | 295x51x30 |
| Weight of umbrella when packaged in carton with spigot (kg) | 49 | 51 | 51 |

Wind guidance*

| | | | |
|---------------------------------|----|----|----|
| Installed wind rating (km/h) | 65 | 65 | 50 |
| Freestanding base rating (km/h) | 30 | 30 | 20 |

*Refer website for more wind guidance information

Base and Installation Options

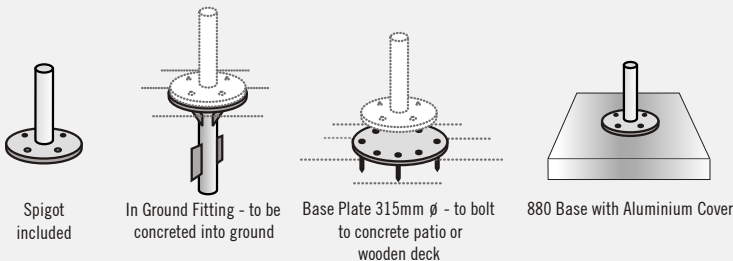

Standard Colours

Canopies are made of Premium 100% Solution Dyed Acrylic Canvas with a 10 year warranty against fading.



Black

Smoked
Tweed

Slate

Natural

*Fabric colours may vary slightly from printed swatches shown above. Other colours available to order, surcharge may apply

Frames

Frames are made of Marine Grade Anodised Aluminium with a 3 year warranty against mechanical defects.



HEAVY DUTY EXTRUDED ALUMINIUM MAST



INFINITY TILT SYSTEM



SILENT CRANKING SYSTEM



EXTRUDED ALUMINIUM JOINTS

Available Australia Wide
Check our website for a dealer near you
www.instantshadeumbrellas.com.au



INSTANT SHADE
UMBRELLAS